

Schnitt A-A

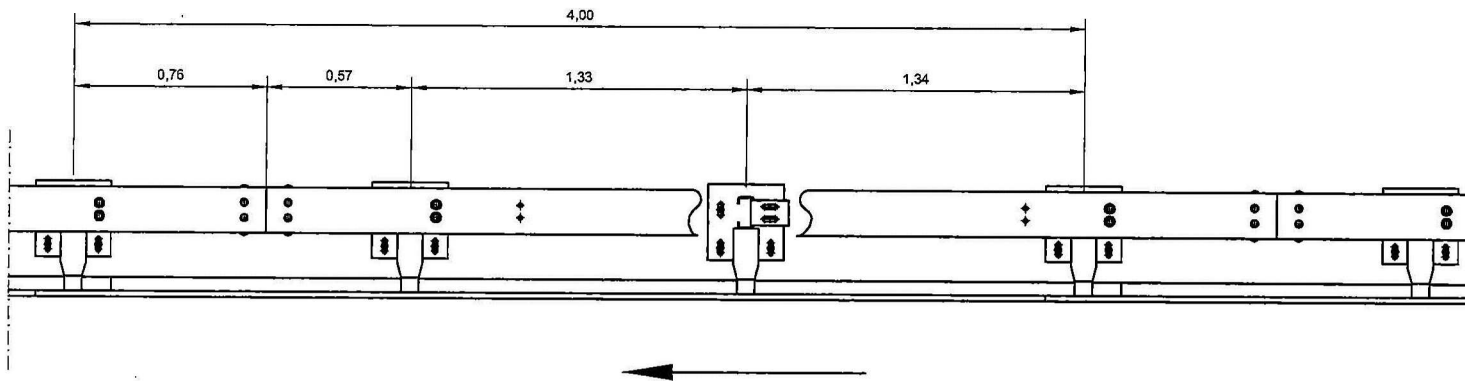
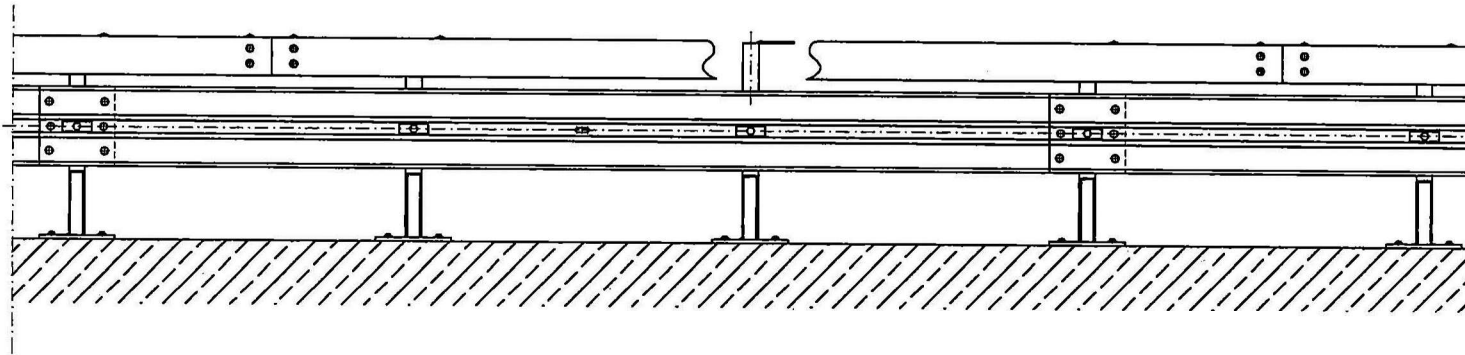
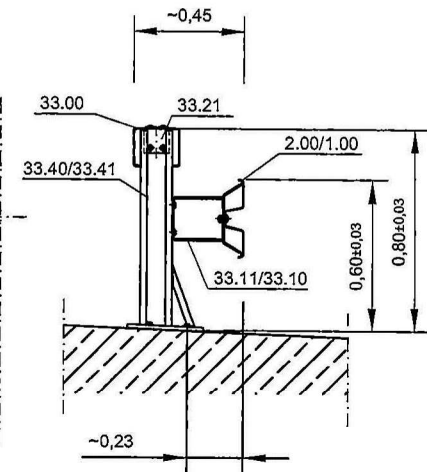

Die Konstruktion ist zum Gebrauchsmuster angemeldet

Verschraubung und Verankerung siehe Zeichnung B1.1-403 und B2.1-208/209

Gütegemeinschaft Stahlschutzplanken e.V.	Zchg. Nr. S1.2-370 Stand: 03/10	<b>SUPER-RAIL Eco auf Bauwerk</b>	DIN EN 1317-2 H2 - W4 - A	
	Profil A: 47,2 kg/m Profil B: 46,2 kg/m			